

Centre Number						Candidate Number				
Surname										
Other Names										
Candidate Signature										

For Examiner's Use	
Examiner's initials	
Question	Mark
1	
2	
3	
4	
5	
6	
TOTAL	



General Certificate of Secondary Education
June 2012

Engineering

48501

Unit 1 Written Paper

Monday 14 May 2012 1.30 pm to 2.30 pm

For this paper you must have:

- normal writing and drawing instruments.

Time allowed

- 1 hour

Instructions

- Use black ink or black ball-point pen.
- Fill in the boxes at the top of this page.
- Answer **all** questions.
- You must answer the questions in the spaces provided. Do not write outside the box around each page or on blank pages.
- Do all rough work in this book. Cross through any work you do not want to be marked.

Information

- The marks for questions are shown in brackets.
- The maximum mark for this paper is 75.
- The questions in Section A relate to the context referred to in the preliminary material that was previously issued.
- You are reminded of the need for good English and clear presentation in your answers. Quality of Written Communication will be assessed in Question 1 (f).



J U N 1 2 4 8 5 0 1 0 1

M/Jun12/48501

48501

SECTION A

Answer **all** questions.

- 1** An electric guitar requires a sound system to function correctly. **Figure 1** shows the circuit diagram of an amplifier.

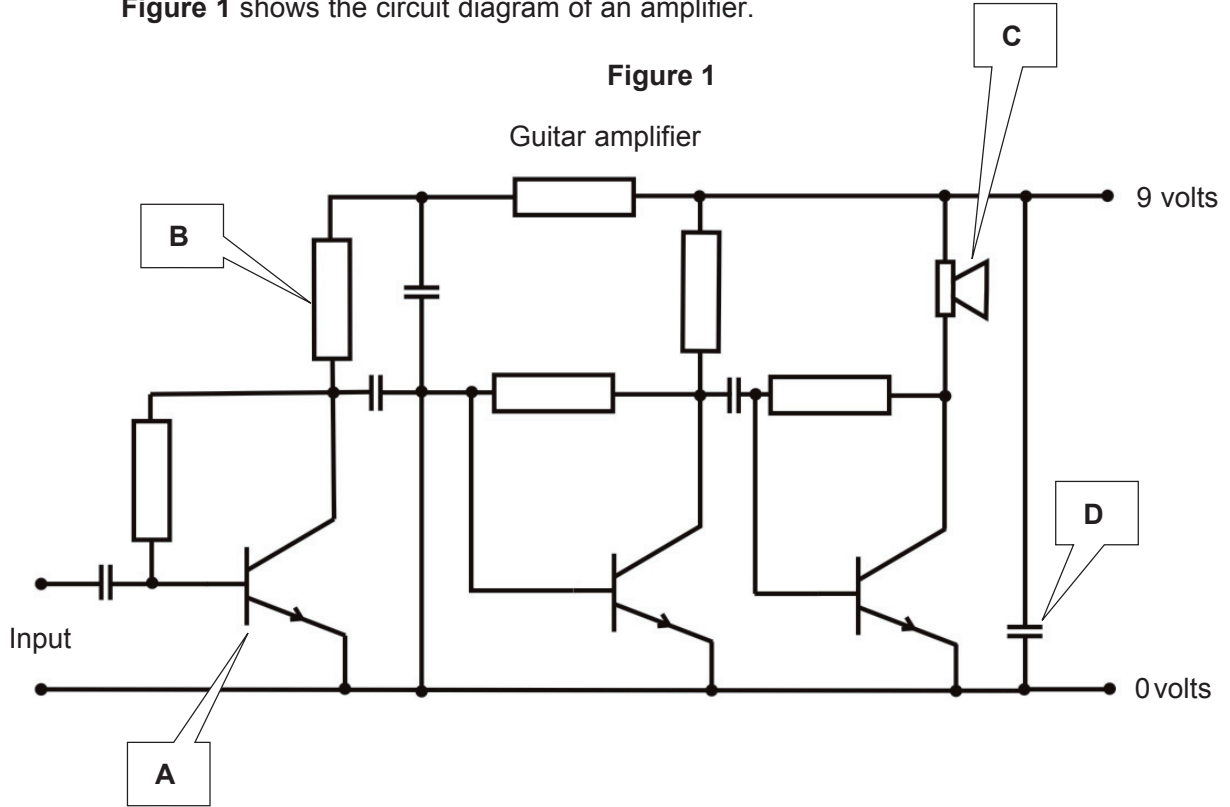

- 1 (a)** In the spaces below, correctly identify each labelled component.

A

.....

B

.....

C

.....

D

.....

(4 marks)



1 (b) Study the picture below, then answer the following questions.

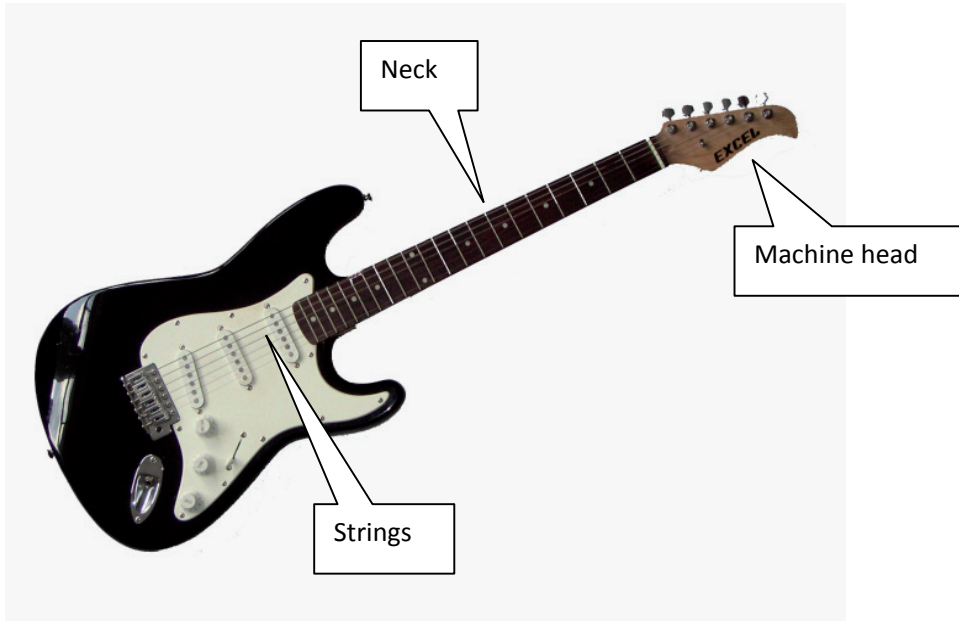

1 (b) (i) Explain why the *neck* of a guitar has to withstand compression.

.....
.....
.....
.....

(2 marks)

1 (b) (ii) Strings have to withstand tension. Explain what is meant by *tension*.

.....
.....
.....
.....

(2 marks)

Turn over ▶



1 (c) Explain how a *machine head* on a guitar works.

.....
.....
.....
.....

(2 marks)

1 (d) In the spaces below, identify **three** pieces of information a designer would need from a client to be able to produce a design for a guitar stand.

1.....
.....
2.....
.....
3.....
.....

(3 marks)



1 (e) Using the three pieces of information you have given in part 1 (d), add relevant details to produce an initial specification statement for a guitar stand.

Specification Point 1

.....
.....
.....

Specification Point 2

.....
.....
.....

Specification Point 3

.....
.....
.....

(6 marks)

Question 1 continues on the next page

Turn over ▶



2 Using notes and sketches, describe how a guitar string is attached to the body of the guitar **and** how the string's vibrations are transmitted.

Marks will be awarded for:

- Information in notes (5 marks)
- Information in sketches (5 marks)

Attachment sketch and notes

Transmission sketch and notes

10

Turn over ►



0 7

SECTION B

Answer **all** questions.

3 Shown below are two electric guitars. Study **Figure 2**, then answer the questions which follow.

Figure 2



3 (a) (i) Explain why the body shape of electric guitars can differ so much.

.....
.....
.....
.....

(2 marks)

3 (a) (ii) Identify a material suitable for making the body of an electric guitar.

.....
.....

(1 mark)



3 (a) (iii) Identify **and** describe a suitable industrial method of producing the body shape for a mass produced electric guitar.

Method

.....

Description

.....

.....

.....

.....

.....

.....

.....

.....

.....

(5 marks)

3 (b) Identify a decorative surface finish **other than polishing**, which can be applied to metal surfaces **and** describe in detail how such a finish could be achieved.

Surface finish

.....

Description

.....

.....

.....

.....

.....

.....

.....

(4 marks)

12

Turn over ▶



4 **Figure 3** below shows the parts of a stainless steel tremolo lever for an electric guitar.

Figure 3

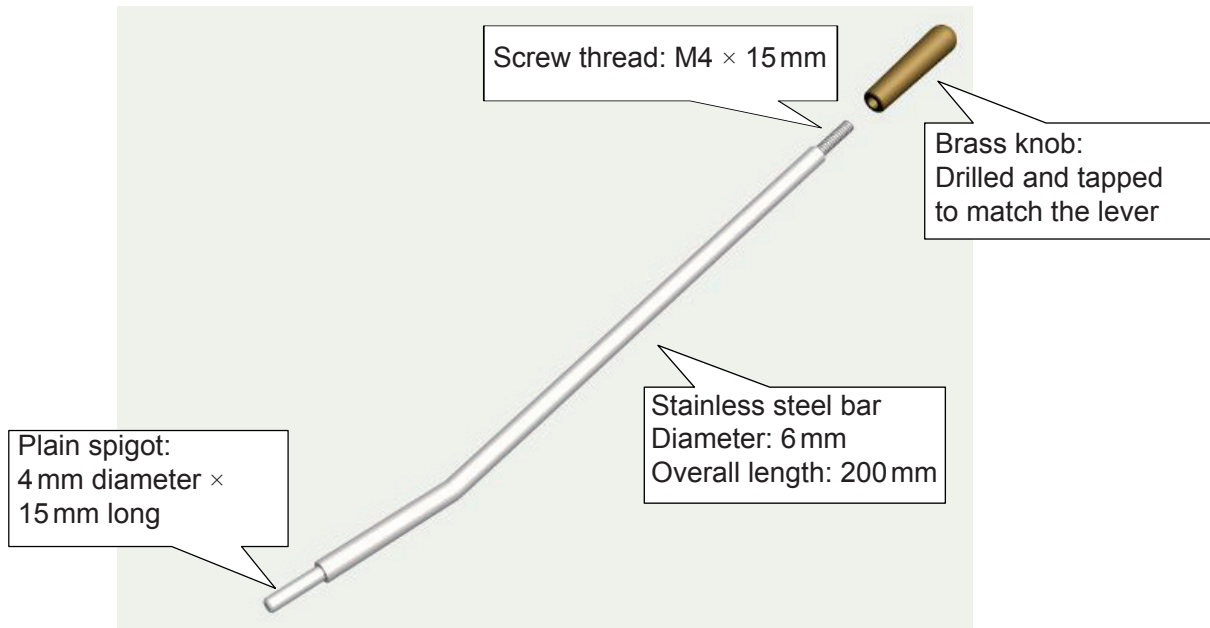

4 (a) Use the information supplied in **Figures 3** and **4** to complete the Front Elevation in **Figure 4** to an appropriate standard by carrying out the following tasks.

4 (a) (i) Complete the front elevation as a sectioned view of the brass knob shown on AA. (4 marks)

4 (a) (ii) Add **one** accurate linear dimension. (2 marks)

Figure 4

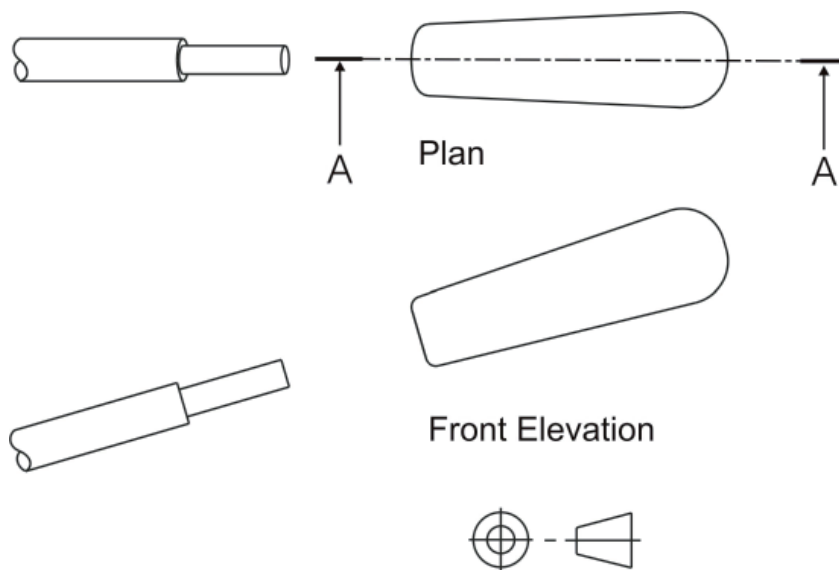

Not to scale



4 (b) In the table below, create a Production Plan listing five major operations needed to complete the tremolo lever to the required specification. Some parts have been done for you. Select the others from the list given below the table by inserting the identification **letter (A to J)** in the appropriate box.

Order	Operation	Tools and equipment	Description of task carried out
1	Material preparation		
2	Turning		
3	Threading		
4	Bending		
5	Polishing		

Use the information below to complete the Production Plan.

Bending jig: **A**

Hacksaw: **F**

Buffing wheel and abrasives: **H**

Position and form 25 degree angle in tremolo lever: **C**

Cut 6 mm stainless steel bar to length: **B**

Produce a high quality shining surface on the lever: **E**

Cut an M4 thread on one end of the machined stainless steel bar to fit the knob supplied: **G**

Reduce stainless steel bar to 4 mm diameter for a distance of 15 mm at each end: **J**

Lathe: **D**

Die and die stock: **I**

(10 marks)

16

Turn over ▶



5 Identify **two** potential health and safety hazards linked to using a centre lathe **and** explain how they can be avoided.

Hazard 1

.....

Explanation 1

.....

.....

.....

Hazard 2

.....

Explanation 2

.....

.....

.....

(6 marks)

6



6 A standard mains electrical plug is shown below.



6 (a) The inner wires have become twisted.

Identify the danger **and** explain in detail how the hazard should have been avoided.

Danger

Explanation

(3 marks)

6 (b) The outer casing of the cable has been damaged and wrapped with tape.

Identify **two** possible dangers this repair could cause.

1

2

How could this cable be safely re-used?

(3 marks)

END OF QUESTIONS

6



There are no questions printed on this page

**DO NOT WRITE ON THIS PAGE
ANSWER IN THE SPACES PROVIDED**



There are no questions printed on this page

**DO NOT WRITE ON THIS PAGE
ANSWER IN THE SPACES PROVIDED**



There are no questions printed on this page

**DO NOT WRITE ON THIS PAGE
ANSWER IN THE SPACES PROVIDED**

Copyright © 2012 AQA and its licensors. All rights reserved.

